

Comparison of Direct Contact Feeding Methods for a Rectangular Microstrip Patch Antenna

P.J. SOH*, M.K.A RAHIM, A.A.H. AZREMI, M.S. ANUAR, A. NURAINUNNAZLI

**School of Computer & Communication Engineering,
Universiti Malaysia Perlis,
02600 Jejawi, Perlis, Malaysia.*

**Corresponding Author. Tel (04) 979 8379, Fax (04) 979 8141
pjsoh@unimap.edu.my*

ABSTRACT

Microstrip patch antennas have a variety of feeding technique applicable to them. It can be categorized in accordance to the main power transfer mechanism from the feed line to the patch. Contacting feeds investigated in this work are coaxial probe feed and transmission line feed. This work is an effort to design, model, simulate, fabricate and measure all four different types of microstrip antenna's non-contacting feed techniques on a similar sized, rectangular patch. Simulation is done using the circuit model (CM) derived from the Transmission Line Model (TLM), and is compared with another simulation set of feeding methods produced using the Method of Moments (MoM). Both methods are simulated on Microwave Office. This design intends to focus on studying the differences in measured and simulated parameters of the patch and its respective feeds, simulate it using MoM, and finally, the fabrication process. Radiation measurements are also presented. Designs for each feeding technique achieved the best return loss (RL) at the desired frequency range, which is 2.4 GHz. The fabricated hardware produced good RL, bandwidth (BW), and comparable radiation performance compared against simulation using MoM. All antennas produced maximum E-and H-plane co- and cross-polarization difference in the magnitude of -18 dB and half-power beam widths (HPBW) in the magnitude of 90°.

Keywords: *Circuit Simulation, Microstrip Antennas, Moment Methods, Transmission Line Matrix*

INTRODUCTION

Microstrip patch antennas (MPAs) have several well-known feeding techniques. Two of the simplest and most important are coaxial probe feed (CPF) and microstrip transmission line feed (TLF). Direct contacting feeds such as CPF and TLF; as its name implies, transfer the power fed into the MPA directly via a conducting feed line connected to the patch conductor⁽¹⁾. Both are preferred due to their simplicity of fabrication process and also adhering to the conformal nature of printed circuit technology.

ANTENNA AND FEED DESIGN

To ensure a fair comparison between the techniques, both feeds are designed to feed a rectangular-shaped microstrip patch antenna. The antenna is designed to resonate at the frequency of 2.4 GHz. A suitable and similar substrate and simulation tool is also chosen to ensure uniformity with least alteration to the feeds' original structure. The substrate used is FR-4, which has a dielectric constant (ϵ_r) of 4.5, dielectric loss tangent ($\tan\delta$) of 0.019 and a single layered substrate height (h) of 1.6 mm. Verification of the comparisons are done by generating two sets of simulation results. A similar simulation software (Microwave Office) is used, but different models are simulated in different simulation environments. One uses the Method of Moments (MoM) while the other applies the Circuit Model/

Schematic (CM), which is derived from the Transmission Line Matrix (TLM). Both differ in terms of numerical assumptions at derivation level, which causes different amount of simulation resources' utilization, at the expense of accuracy. In other words, TLM will cost least time and simulation resources, but it will produce a less accurate results, while MoM will produce more accurate results and at the same time take up more resources. Fabrication of the hardware is done using the wet-etch technique on a FR-4 photo board, which layouts are similar to MoM based simulations. Hardware measurement values are collected, compared and analyzed against the simulation results.

In order to design a patch resonating at a similar frequency, which is 2.4 GHz, the equations in Table 1 are used. However, a significant upwards shift in resonant frequency (f_{res}) has been reported in⁽²⁾. Therefore before designing the patch a lower design frequency is necessary. The shift values have been determined experimentally to compensate for the amount of upward shifts. A batch of prototype with different feeds has been fabricated and its amount of shift calculated so that it could be taken into consideration when designing for the actual prototypes. Its results are shown in Table 2 and 3.

Table 1. The design equations for different parameters in designing an MPA.

Step	Parameter	Design Equation	Legend
1	Patch Width (W)	$W = \frac{1}{2f(\sqrt{\epsilon_o\mu_o})} \sqrt{\frac{2}{\epsilon_r + 1}}$	ϵ_{reff} = effective dielectric constant
2	Effective Dielectric Constant (ϵ_{reff})	$\epsilon_{reff} = \left(\frac{\epsilon_r + 1}{2}\right) + \left[\left(\frac{\epsilon_r - 1}{2}\right) \left[1 + 12 \frac{h}{W}\right]^{-0.5}\right]$	h = substrate height
3	Patch Length Extension (ΔL)	$\Delta L = 0.412h \frac{(\epsilon_{reff} + 0.3) \left(\frac{W}{h} + 0.264\right)}{(\epsilon_{reff} - 0.258) \left(\frac{W}{h} + 0.8\right)}$	W = patch width ϵ_r = relative dielectric constant
4	Patch Length (L)	$L = \left(\frac{1}{2f\sqrt{\epsilon_{reff}}\sqrt{\epsilon_o\mu_o}}\right) - 2\Delta L$	μ_o = permeability in free space
5	Effective Patch Length (L_e)	$L_e = L + 2\Delta L$	L_e = relative dielectric constant ΔL = patch length extension

Calculated values are approximate values of the resonant parameters, but minor tweaking to the values provided by the software is necessary to achieve optimal simulation results at desired resonance.

FEED MODELS AND ARCHITECTURE

Coaxial Probe Feed (CPF)

A coaxial probe fed microstrip patch antenna (CPF-MPA) is fed using a coaxial probe which outer conductor is connected to the bottom ground plane. Its inner conductor extends further upwards to connect to the patch. Impedance control is done using the probe position.

Table 2. Amount of resonant frequency shift determined experimentally.

Type of Feed	Rep Model	Resonant Freq (GHz)	Freq Shift (%)	New Design Freq (GHz)	Calculated at new freq		Actual	
					W(mm)	L (mm)	W (mm)	L (mm)
Coaxial Probe Feed	MoM	2.45	4.583	2.29	38.302	29.600	37.000	30.000
	Meas	2.56						
Microstrip Transmission Line Feed	MoM	2.41	2.075	2.36	39.473	30.522	39.000	29.000
	Meas	2.48						

Probe feed mechanism is in direct contact with the antenna, and most of the feed network is isolated from the patch. This provides an efficient feeding and minimizes spurious radiation⁽²⁾. Connection of the different inner and outer conductors to the different layers of patch, and the existence of a vertical interconnection complicates fabrication of this antenna type. It also produces small bandwidth (BW), and might generate high cross-polarized fields when electrically thick substrates are used⁽³⁾. The structure of this feeding technique is shown in Figure 1, and its equivalent circuit in Figure 2. The parallel RLC circuit represents the matched resonating patch, which is about 50 Ω in complex value. Feed reactance is a combination of the inductive feed and the capacitive feed reactance between the patch and the ground. The coaxial probe is matched to the patch using three components (two inductors, L₁ and L₂, and a resistor, R₁ in series), while the parallel capacitor value represents the probe's capacitance. For MoM simulation, the design dimensions are shown in Figure 3.

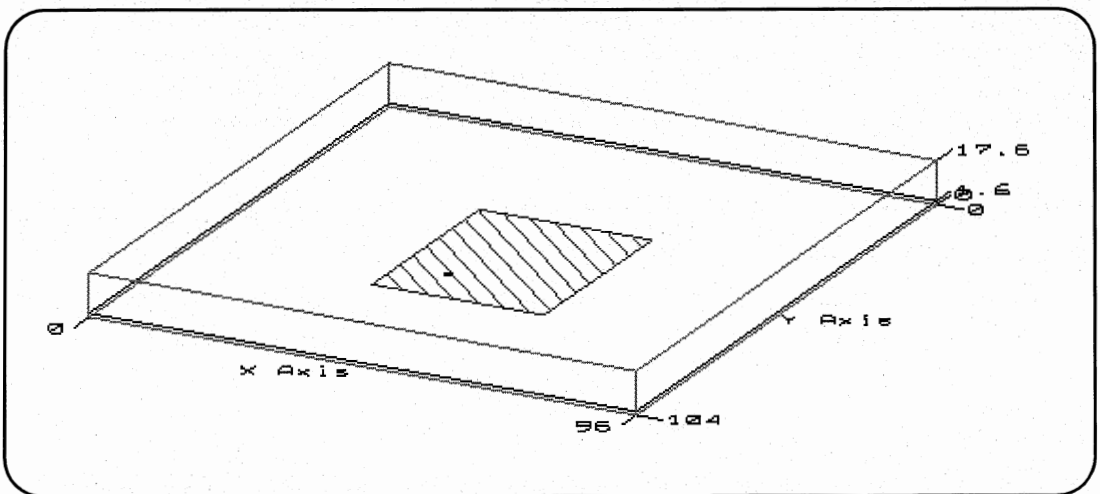

Figure 1. The 3D structure of the coaxial probe fed microstrip patch antenna.

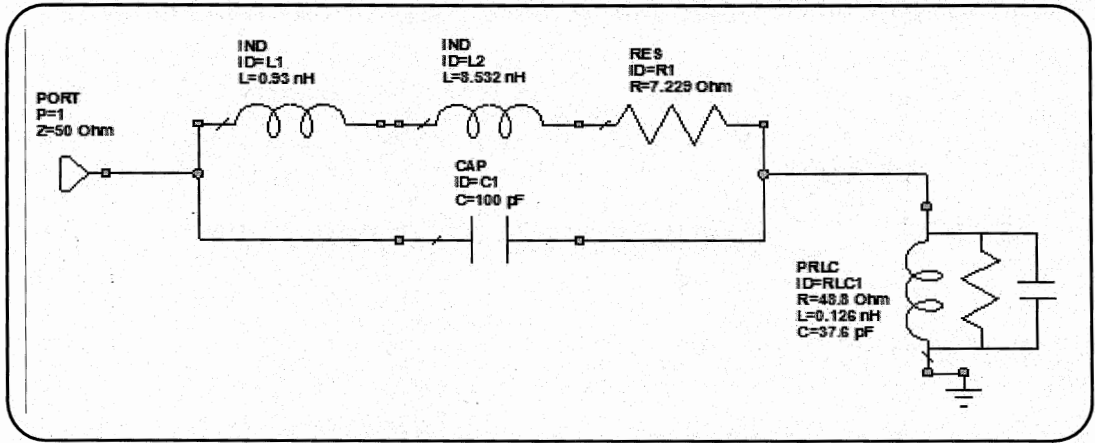

Figure 2. The equivalent circuit for coaxial probe fed microstrip patch antenna.

Microstrip Transmission Line Feed (TLF)

A microstrip transmission line-fed patch antenna (TLF-MPA) is generally made up feed line of a certain width and length (W_f and L_f), and connected to a specific matching stub of corresponding width and length (W_s and L_s). Its structure is shown in Figure 4.

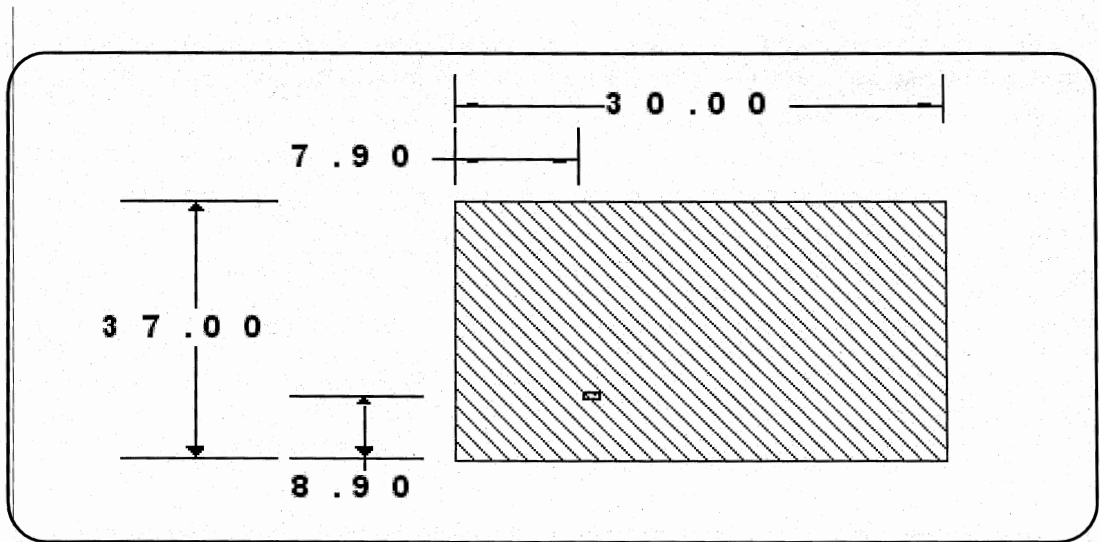

Figure 3. Dimension of the coaxial probe fed antenna.

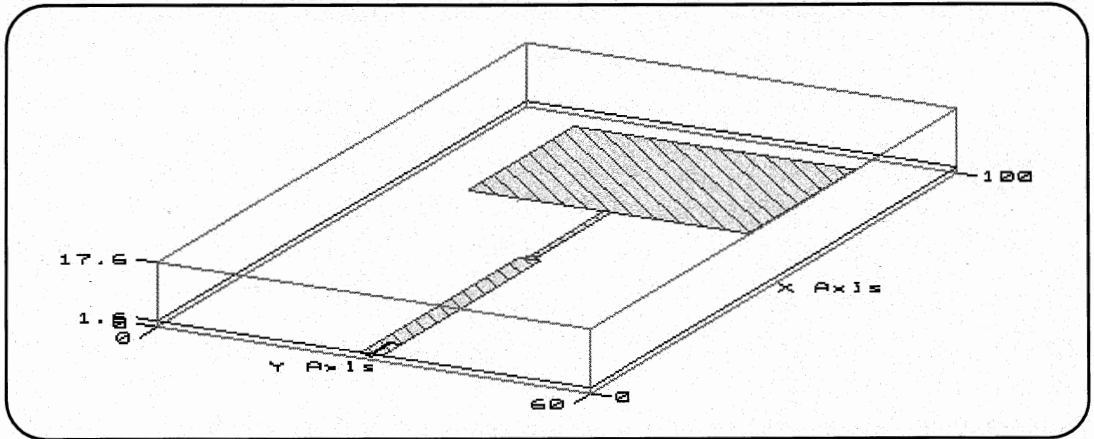

Figure 4. The 3D structure of the microstrip transmission line fed patch antenna.

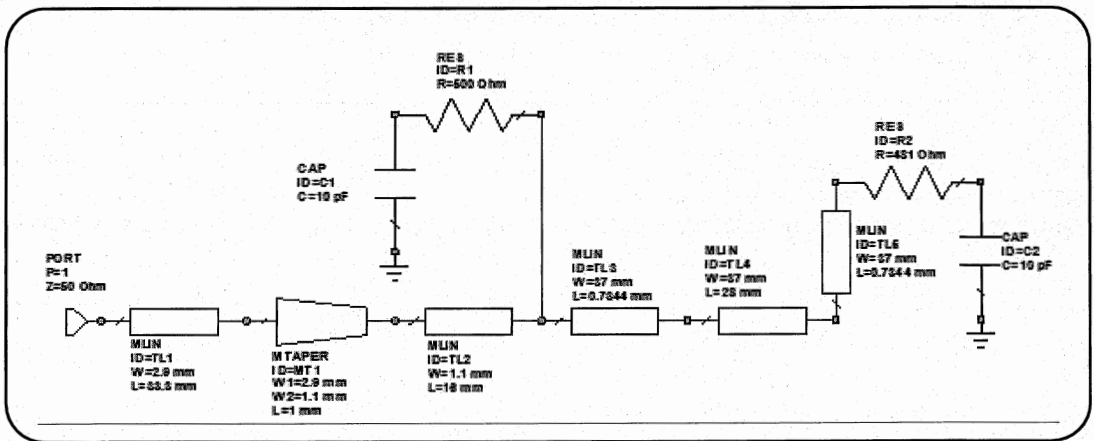

Figure 5. The equivalent circuit of the microstrip transmission line fed patch antenna.

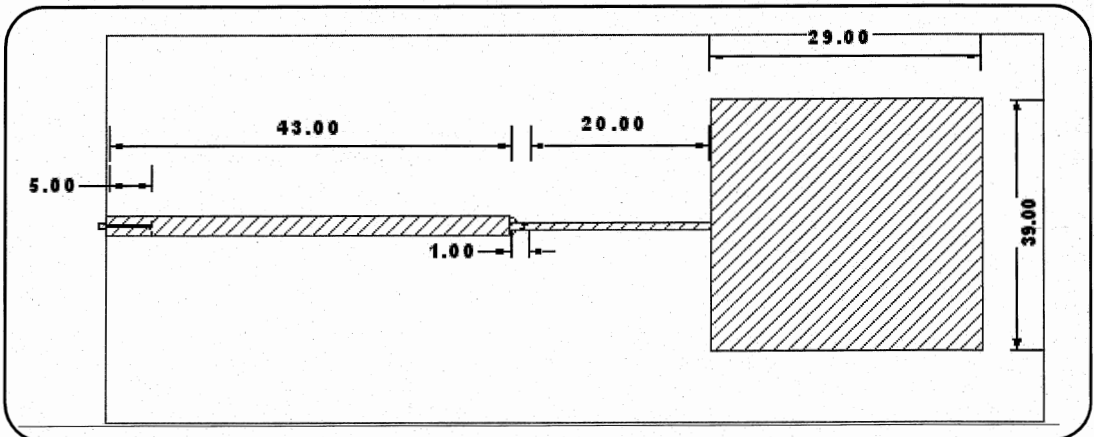

Figure 6. Dimension for the transmission line fed antenna.

RESULTS AND DISCUSSION

MoM Simulated and Circuit Simulated Comparison

The summary of all simulated RL and BW are compiled in Table 3. It can be seen that most CMs has a large BW deviation in comparison with its MoM simulation results. Although this could reflect serious modeling defect, it also is contributed by the properties of the CM itself. In fact, CMs derived from TLM has the incapability of modeling couplings^(1,7). The larger BW difference between MoM and CM is produced by the CPF-MPA, up to 16%, which shows that proper improvement is needed for the model, especially in modeling the through hole and SMA connector at the bottom of patch. The TLF-MPA, on the other hand, has been represented by a very accurate model. This feed deviates less than 1% in terms of BW when CM is compared against MoM. The circuit has been made up of microstrip lines which also ease the understanding when compared to the physical layout structure⁽⁷⁾. Dimensions of the lines can easily be changed. Instead of representing the fringing fields as the conventional parallel RLC line, the circuit is accurately defined using the series RC element.

Table 3. MoM and circuit simulated RL, f_{res} and BW.

Type of Feed	Rep Model	Return Loss (dB)	Resonant Freq (GHz)	Bandwidth (%)	Res Freq Variation (%)	Bandwidth Variation (%)
Coaxial Probe Feed	MoM	-31.760	2.290	2.180	0.866	16.154
	Circuit	-32.660	2.310	2.600		
Microstrip Transmission Line Feed	MoM	-22.480	2.360	2.540	0.840	0.787
	Circuit	-23.619	2.380	2.520		

Despite all the large differences in BW, the CM and MoM simulated results for each feed produced rather similar RLs. Since all feeds managed to produce a good RL (< -10 dB), the differences will not be as critical as it is for the BW⁽¹¹⁾.

Direct contact feeds i.e CPF-MPA and TLF-MPA; have deviations of less than 1% in terms of f_{res} from equivalent circuit in comparison with MoM. Thus these CMs can be used effectively when a direct contact feed is used, as it provides a more accurate result of the f_{res} .

Another possible contributor to the f_{res} differences between the MoM and CM results is due to the accuracy of the dimensions used. CMs that utilize transmission lines can be easily defined for its dimension, and a value of up to four decimal points can be used to define a certain part of its width and length. In contrast, the MoM simulated circuit has a practical capability of up to 0.1 mm resolution per simulation mesh of the enclosure. Lower sized mesh would be impractical, and would cost a lot in terms of simulation time and resources^(3,11).

MoM Simulated and Measurement Result Comparison

The comparison of the results in terms of BW and RL between the simulated and the measured is summarized in Table 4. The RLs generated by both feeds, which are all in the magnitudes of less than -20 dB, shows that a good impedance matching has been achieved in both designs. The better RL is shown by the CPF-MPA, which proves that the direct contact feeds easily matched as its exposed power mechanism involved is minimal. The exposed line in TLF-MPA, which is the main power transfer mechanism, is prone to spurious radiation. It is easily affected by external elements, especially when working in a practical environment⁽³⁾.

The different BW ranges produced by different MPAs are within range, as per stated in various literatures. The TLF-MPA produced the lowest measured result, and at the same time also produced the highest deviation from its simulated BW. This is caused by the feed line, which suffers serious spurious radiation in practice^(2,6).

Table 4. The summary and comparison of the measured and simulated RL, f_{res} and BW.

Type of Feed	Rep Model	RL (dB)	Resonant Freq (GHz)	Bandwidth (%)	Res Freq Var from 2.4GHz (%)	BW Variation (%)
Coaxial Probe Feed	MoM	-31.760	2.290	2.180	1.031	1.357
	Meas	-23.350	2.425	2.210		
Microstrip Transmission Line Feed	MoM	-22.480	2.360	2.540	0.415	18.503
	Meas	-30.770	2.410	2.070		

The CPF-MPA generated a difference of less than 6.5 % between MoM and measurement it has not any feeding element which has an exposed line like the transmission line fed antenna does.

During the design stage, the hardware's upward f_{res} shift has already been compensated for. However, there still exist a small amount of f_{res} shifting from the intended design frequency of 2.4 GHz in the final measurement values. The lower frequency shift from 2.4 GHz is shown by the transmission line feed. The fabricated hardware resonates at a frequency of 2.41 GHz, which is only less than 0.5 % in difference. The reoccurrence of the shifts are caused by several factors. First, the dielectric material used in this work, which is the FR-4 has a relative dielectric constant that varies from 4.0 to 4.8⁽¹²⁾, depending on the operation frequency. Unlike the constant dielectric constant defined in simulations, the material has also a varying ϵ_r value along the width, height and length of the structure in practice^(3,7,10,11). This will also contribute to the unexpected shift in f_{res} , and better hardware measurements results could be produced when compared to simulation.

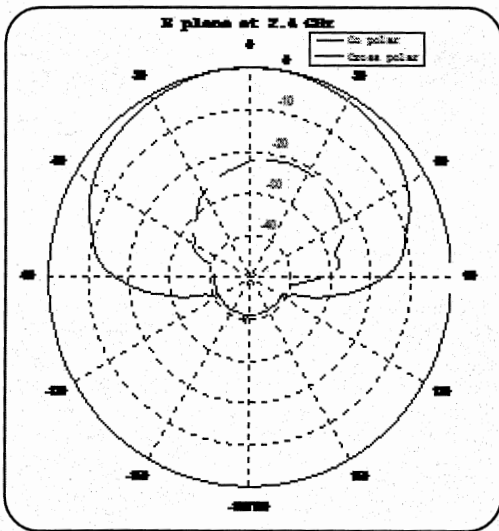

Figure 7(a). E plane polar radiation pattern for coaxial probe feed.

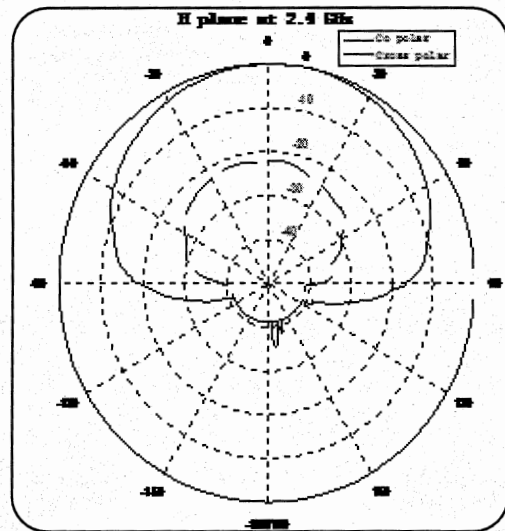

Figure 7(b). H plane polar radiation pattern for coaxial probe feed.

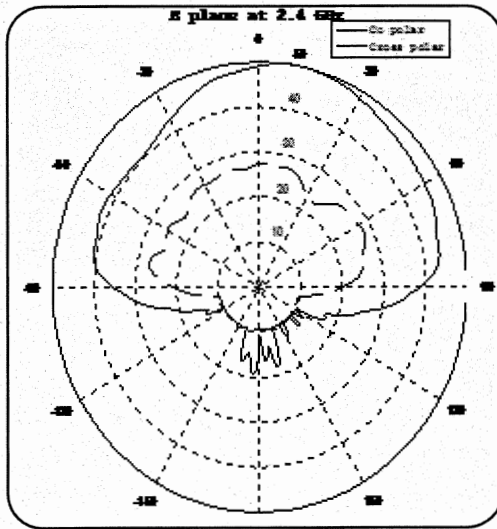

Figure 8(a). E plane polar radiation pattern for transmission line feed.

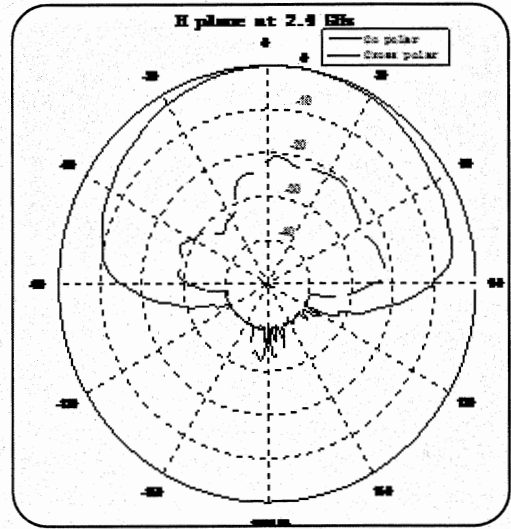

Figure 8(b). H plane polar radiation pattern for transmission line feed.

Etching accuracy is also another factor to be considered; as a small change in patch's or feed's length could shift the f_{res} up to a certain amount, especially when operating in a high frequency like this. The type of chemical used, surface finish and metallization thickness are other factors that could affect the etching accuracy^(3,7,10,11).

Simulated and Measured Radiation Characteristics

Both fabricated antennas produced satisfactory values on both E and H plane (HPBW > 20 dB). It also shows large isolations and half-power beam width (HPBW) on both E and H planes. Measured radiation patterns for all antennas, are shown in Figs. 7-8, while numerical results are listed in Table 5. Since a broader E plane HPBW is produced by a smaller substrate thickness (h)⁽³⁾ both MPAs are expected to produce large E plane HPBW. This is proven true when CPF-MPA showed broadest HPBW pattern in E Plane, followed by TLF-MPA since both have the same values of h .

The H plane HPBW grows inversely proportionate with larger W . Due to reason, the ACF-MPA again to have the largest H plane HPBW, since its patch has the largest value of W . CPF-MPA also produced a slightly lower, but almost equivalent value since it has a W value similar to CPF-MPA.

Comparison of difference between the simulated and measured HPBW shows that the highest percentage is evident in TLF-MPA (about 8%). This is caused by the spurious radiation imminent along the length of the feed, thus reducing the power available for input to patch and affects matching.

In terms of gain and directivity, the simulated values of each antenna produced slightly larger value as compared to measured. This is a proof of slight losses when the antennas are operated in practice. The lower measured gain among the two is produced by CPF-

MPA, while TLF-MPA showed a higher gain level. This is directly related to the E plane HPBW characteristic, where a narrower E plane will produce a larger gain at a specific direction ⁽¹¹⁾. In this study, the CPF-MPA produced the largest E plane (HPBW of 96°) which is the main cause of its poor gain characteristics. In contrast, the highest gain is produced by TLF-MPA, which has the narrower E plane HPBW.

The isolation levels produced by both feeds are at an acceptable level. TLF-MPA produced a lower isolation of the two, indicating the power loss and coupling to other environmental polarization along the exposed feed line is imminent ⁽⁸⁾. The higher isolation at both E and H plane is produced by CPF-MPA, due to its h, moderate W and low cross polarization level ^(3,11).

From the results, it is concluded that the gain is more influenced by the E plane isolation rather than the H plane isolation. The higher the isolation is, the better its gain and directivity values produced ⁽⁸⁾. It is also shown in this analysis that both direct contacting feeds suffer a higher level of losses, up to 88% to 90%.

CONCLUSIONS

A method of design, optimization, fabrication, measurement and result analysis is presented in comparing two most common direct contact feeding techniques to a microstrip patch antenna. The design and simulation has utilized the process equations and structural simulation tools. A circuit model for each type of feed and its parameter calculation equations is also adopted in this work. All antennas designed and measured are proven operable, with a sufficient amount of return loss, gain, and radiation characteristics in the 2.4 GHz ISM Band.

ACKNOWLEDGEMENT

The authors would like to express sincere thanks to the project's supervisor, Dr Mohd Kamal, peers and staff from the Wireless Communication Centre (WCC), Universiti Teknologi Malaysia for their kind contributions and enlightening discussions.

Table 5. The summary and comparison of the measured and simulated HPBW, Gain and Directivity.

Parameters		CPF-MPA		TLF-MPA	
		E-Plane	H-Plane	E-Plane	H-Plane
Max co-polarization (-dBm)		-8.93	-8.91	-9.59	-10.32
Max cross-polarization (-dBm)		-30.10	-30.75	-31.56	-31.08
Isolation at 0° (dB)		21.18	21.84	21.99	20.76
HPBW (°)	Sim	101.5	110.2	102.5	100.6
	Meas	96.0	106.0	94.0	92.0
Directivity (dB)	Sim	7.0699		7.2092	
	Meas	7.0150		7.1470	
Gain (dB)	Sim	6.2605		6.5177	
	Meas	6.064		6.2130	

REFERENCES

- Godara, L.C. ed. (2002). *Handbook of Antennas in Wireless Communication*. Florida: CRC Press LLC
- Vajha, S., and Prasad, S.N. (2000). Design and Modeling of a Proximity Coupled Patch Antenna. *Conference on Antennas and Propagation for Wireless Communications*. 6-8 Nov. Massachusetts: IEEE-APS, 43-46
- Garg, R., Bhartia, P., Bahl, I., and Ittipiboon, A. (2001). *Microstrip Antenna Design Handbook*. London: Artech House.
- James, J. R., and Hall, P. S., (1989), *Handbook of Microstrip Antennas*, London: Peter Peregrinus Ltd
- Kapsidis, D., Chryssomallis, M.T., and Christodoulou, C.G. (2003). An Accurate Circuit Model of a Microstrip Patch Antenna for CAD Applications. *Antennas and Propagation Society International Symposium*. 22-27 June. Greece: IEEE, 120-123
- Balanis, C.A. (1997). *Antenna Theory: Analysis and Design*. 2nd Ed. New York: John Wiley and Sons
- Soh, P.J., Rahim, M.K.A., Asrokin, A., Abdul Aziz, M.Z.A. (2005). Modeling of Different Feeding Techniques for a Microstrip Patch Antenna. *MMU International Symposium*

on Information and Communications Technologies (M2USIC'05), Proceedings of the. Nov 24th-25th. Malaysia: Malaysia Multimedia University (MMU), TS05 p.p9-13

8. Soh, P.J., Rahim, M.K.A., Asrokin, A. (2006). Design, Modeling and Comparison of Non-Contacting Feeds for a Microstrip Patch Antenna, *IEEE International Conference on Computer & Communication Engineering (ICCCE 06)*. May 9th – 11th. Malaysia: IEEE Malaysia Chapter
9. Asrokin, A., Rahim, M.K.A., Soh P.J., (2006). Slotted Square Microstrip Antenna Using the Proximity Feeding Technique for Dual Band Application, *IEEE International Conference on Computer & Communication Engineering (ICCCE 06)*. May 9th – 11th. Malaysia: IEEE Malaysia Chapter
10. Soh, P.J., Rahim, M.K.A., Asrokin, A., Abdul Aziz, M.Z.A. (2005). Comparative Studies on Performance of Different Feeding Techniques Using Circuit Model for a Microstrip Patch Antenna. *IEEE Asia Pacific Conference on Applied Electromagnetics (APACE '05), Proceedings of the. Dec 20th-21st. Malaysia: IEEE AP/MTT/EMC Joint Chapter.*
11. Soh, P.J., (2005), *Microstrip Antenna with Different Feeding Techniques*, Universiti Teknologi Malaysia: M. Eng. Thesis
12. Rahim, M.K.A (2003), *Wideband Active Antenna*, University of Birmingham: Ph.D. Thesis